

# ZYTM285系列推拉门结构图

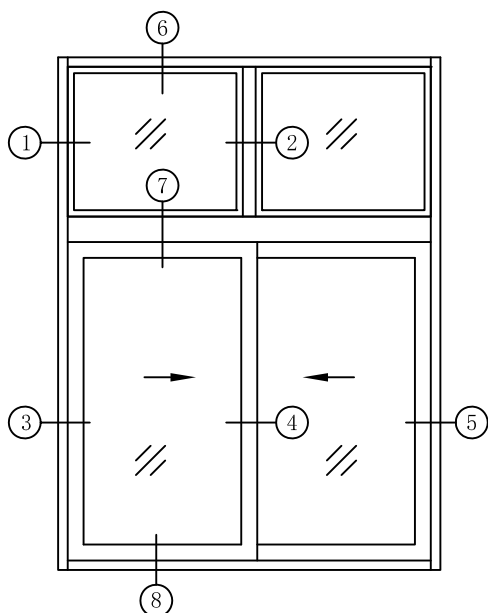

标准门: 1.8mX2.4m, 耗材约5.2kg/m<sup>2</sup>。

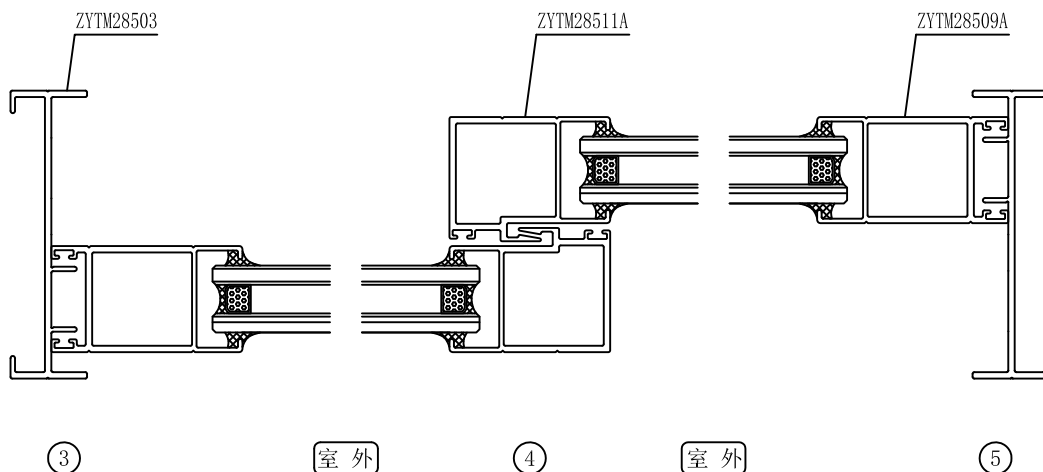
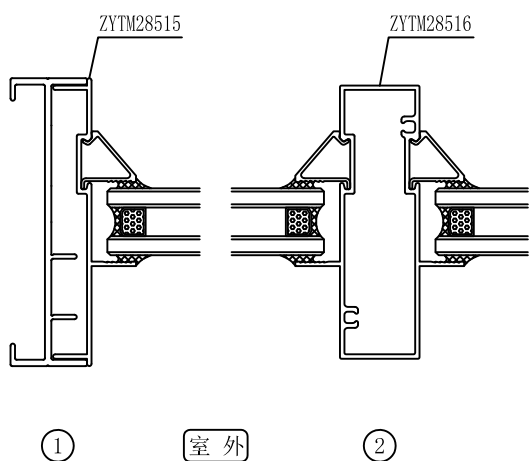
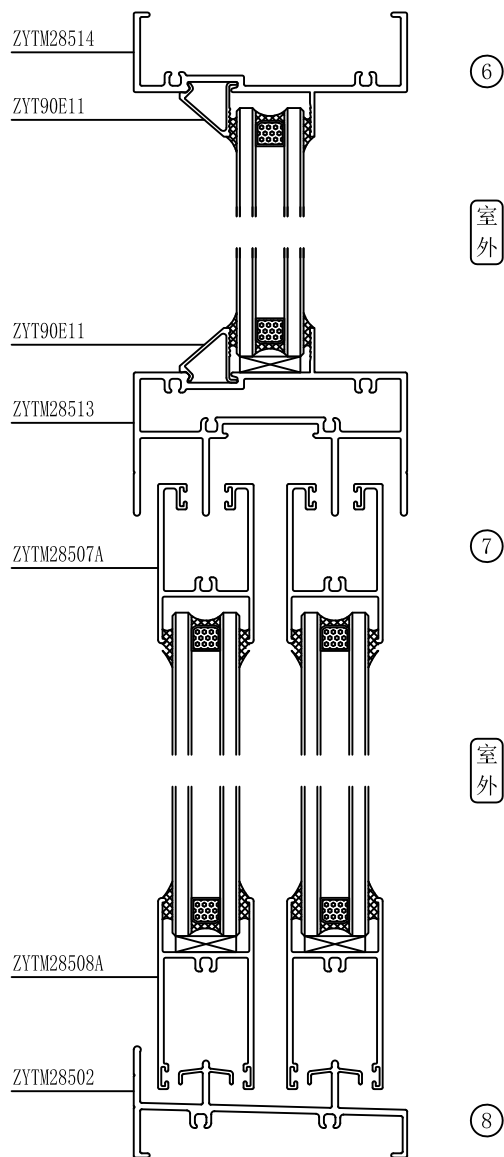

# ZYTM285系列推拉门结构图(四扇带固定)

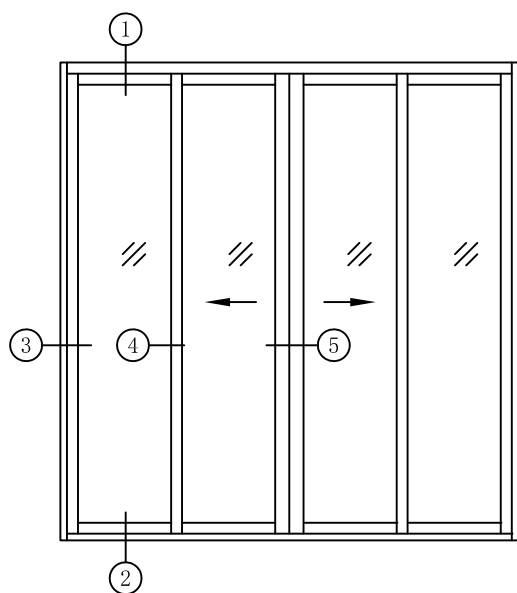

标准门: 3.4mX2.2m, 耗材约4.1kg/m<sup>2</sup>。

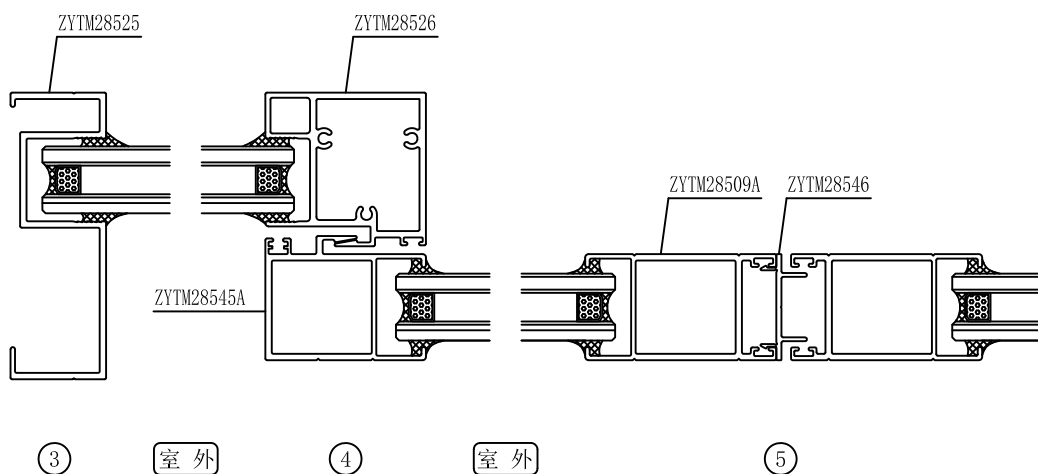
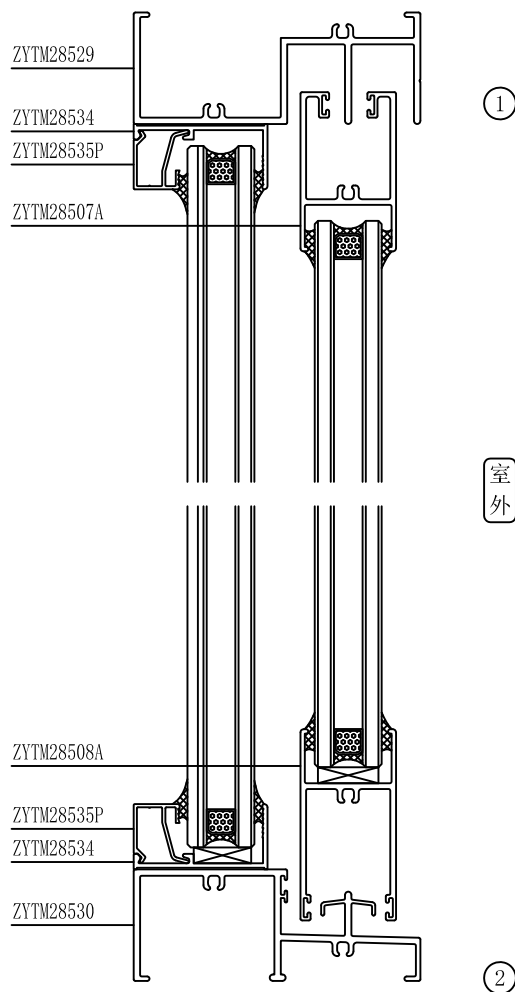

# ZYTM285系列推拉门型材目录

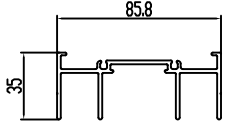
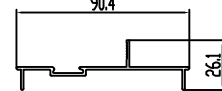
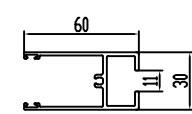
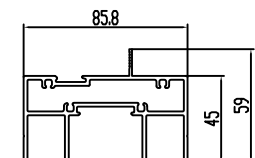
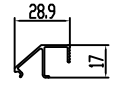
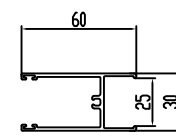
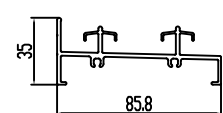
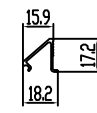
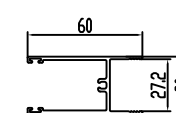
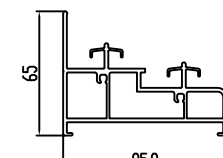
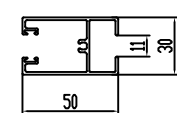
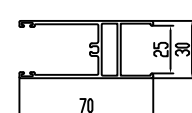
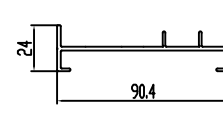
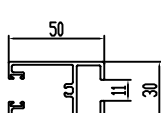
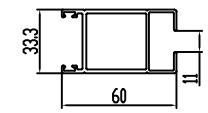
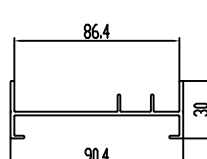
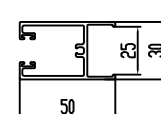
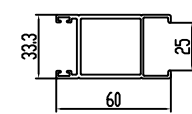
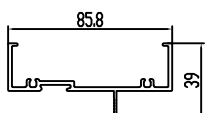
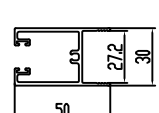
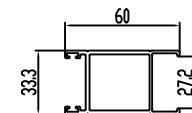
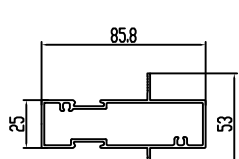
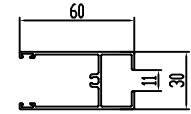
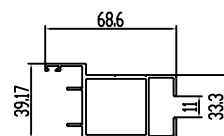
型材编号	图 例	型材编号	图 例	型材编号	图 例
名称		名称		名称	
壁厚T(mm)		壁厚T(mm)		壁厚T(mm)	
重量(kg/m)		重量(kg/m)		重量(kg/m)	
ZYTM28501 上滑 T=2.0 1.209 kg/m		ZYTM28515 边封插板 T=1.4 0.511 kg/m		ZYTM28508D 下方 T=2.0 0.846 kg/m	
ZYTM28513 固上滑 T=2.0 1.903 kg/m		ZYTM28518 压线 T=1.0 0.177 kg/m	 槽口: 12mm	ZYTM28508A 双玻下方 T=1.8 0.732 kg/m	
ZYTM28502 下滑 T=2.0 1.089 kg/m		ZY90E11 双玻压线 T=0.9 0.123 kg/m	 槽口: 25mm	ZYTM28508C 双玻下方 T=1.8 0.715 kg/m	
ZYTM28554 下滑 T=2.0 1.930 kg/m		ZYTM28507 上方 T=1.4 0.702 kg/m		ZYTM28555 高下方 T=1.8 0.935 kg/m	
ZYTM28503 边封 T=2.0 0.830 kg/m		ZYTM28507D 上方 T=2.0 0.860 kg/m		ZYTM28509 光企 T=2.0 0.961 kg/m	
ZYTM28531 边企 T=2.0 0.900 kg/m		ZYTM28507A 双玻上方 T=1.8 0.751 kg/m		ZYTM28509A 双玻光企 T=2.0 0.912 kg/m	
ZYTM28514 上固 T=2.0 0.901 kg/m		ZYTM28507C 双玻上方 T=1.8 0.732 kg/m		ZYTM28509B 双玻光企 T=2.0 0.897 kg/m	
ZYTM28516 中柱 T=1.4 1.065 kg/m		ZYTM28508 下方 T=1.4 0.679 kg/m		ZYTM28510 收口光企 T=2.0 0.999 kg/m	

# ZYTM285系列推拉门型材目录

型材编号	图 例	型材编号	图 例	型材编号	图 例
名称		名称		名称	
壁厚T(mm)		壁厚T(mm)		壁厚T(mm)	
重量(kg/m)		重量(kg/m)		重量(kg/m)	
ZYTM28510A 双玻收口光企 T=2.0 0.947 kg/m		ZYTM28512A 加强勾企 T=1.9 1.343 kg/m			
ZYTM28544 加强光企 T=2.0 1.358 kg/m		ZYTM28545B 加强勾企 T=1.9 1.339 kg/m			
ZYTM28511 勾企 T=2.0 0.947 kg/m	 <small>注：与ZYTM28554不配套</small>	ZYTM28517A 收口 T=1.2 0.314 kg/m			
ZYTM28545 勾企 T=2.0 0.946 kg/m		ZYTM28546 收口 T=1.6 0.220 kg/m	 <small>注：与ZYTM28509不配套</small>		
ZYTM28511A 双玻勾企 T=2.0 0.895 kg/m	 <small>注：与ZYTM28554不配套</small>	ZYTM28527 收口 T=1.4 0.369 kg/m			
ZYTM28545A 勾企 T=2.0 0.894 kg/m					
ZYTM28511B 双玻勾企 T=2.0 0.881 kg/m	 <small>注：与ZYTM28554不配套</small>				
ZYTM28512 加强勾企 T=1.9 1.395 kg/m					

# ZYTM285系列推拉门型材目录(四扇带固定部分)

型材编号	图 例	型材编号	图 例	型材编号	图 例
名称		名称		名称	
壁厚T(mm)		壁厚T(mm)		壁厚T(mm)	
重量(kg/m)		重量(kg/m)		重量(kg/m)	
ZYTM28536 单轨上滑 T=1.4 0.905 kg/m		ZYTM28526 固定勾企 T=2.0 1.271 kg/m			
ZYTM28529 单轨上滑 T=2.0 1.211 kg/m		ZYTM28534 底座 T=1.4 0.266 kg/m			
ZYTM28537 单轨下滑 T=1.4 0.902 kg/m		ZYTM28540P 单玻固定压线 T=1.0 0.201 kg/m			
ZYTM28530 单轨下滑 T=2.0 1.160 kg/m		ZYTM28535P 压线 T=1.0 0.163 kg/m			
ZYTM28538 固定单玻边封 T=1.4 0.732 kg/m					
ZYTM28525 固定边封 T=2.0 1.092 kg/m					
ZYTM28528 边封 T=2.0 0.897 kg/m					
ZYTM28539 单玻固定勾企 T=2.0 1.304 kg/m					